

C100 SERIES

Flat Roof Ventilator

CHARACTERISTICS

- Easy-to-install, hardware included
- 24-26 ga. galvanized steel construction
- Available with a 45 degree base or with a flat insulated base
- Wind deflector construction
- Maintenance free
- Polyester powder coat finish
- Standard colours: black, brown and grey
- Custom colours available upon request

DETAILS AND DESCRIPTION

- 1-wing design allows for optimal flat roof ventilation.
- Solid structure from one central cube with grid-style perforations, eliminating maintenance required by standard mesh-style openings, while still preventing rodents and birds from entering your attic.
- Wind deflector construction prevents bad weather infiltration from all wind directions.
- 12" unit ventilates up to 150 sq. ft area.
- Works with a combination of wind and pressure differentials creating a vacuum effect.
- Allows for a cooler house in the summer by eliminating heat that accumulates inside the house, avoiding seepage and other problems.

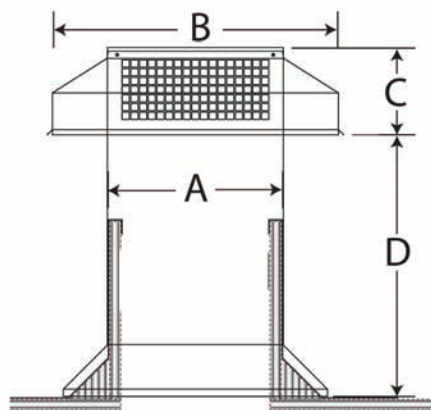

- Promotes a dryer attic in the winter by allowing vapour to escape rather than condensate, thus avoiding mildew and ice formation.
- Saves energy all year round.
- Overall design prolongs the structural integrity of your building.
- Conforms to the requirements for ventilation of unrestricted air space for flat roofs mandatory under the National Building Code, as described in Sec. 9.19.1 and/or by ACNIR CAN-A93-M82, at a ratio of 1/150.
- Limited 5-year warranty on material only, provided product was installed as per manufacturer's recommendations.

PRODUCT	DIMENSIONS				EVACUATION	
	A	B	C	D	Model C100	Steel gauge used
C112 SERIES	12 in (30.5 cm)	19.5 in (49.5 cm)	5.25 in (13.3 cm)	18 in (45.7 cm)	144 in ² (930.25 cm ²)	26
C114 SERIES	14 in (35.6 cm)	24 in (60.9 cm)	7.25 in (18.4 cm)	20 in (50.8 cm)	196 in ² (1267.36 cm ²)	26
C116 SERIES	16 in (40.6 cm)	26 in (66 cm)	7.25 in (18.4 cm)	20 in (50.8 cm)	256 in ² (1648.36 cm ²)	26
C118 SERIES	18 in (45.7 cm)	28 in (71.1 cm)	7.25 in (18.4 cm)	20 in (50.8 cm)	324 in ² (2088.49 cm ²)	24 & 26
C120 SERIES	20 in (50.8 cm)	32 in (81.2 cm)	10.25 in (26.4 cm)	20 in (50.8 cm)	400 in ² (2580.64 cm ²)	24 & 26
C122 SERIES	22 in (55.8 cm)	34 in (86.3 cm)	10.25 in (26.4 cm)	20 in (50.8 cm)	484 in ² (3113.64 cm ²)	24
C124 SERIES	24 in (60.9 cm)	36 in (91.4 cm)	10.25 in (26.4 cm)	20 in (50.8 cm)	576 in ² (3708.81 cm ²)	24

- Insulated base can be extended up to 12 inches
- Custom dimensions available upon request
- Sizes 14 to 24 inches are available by special order only

Visit our video channels: <https://vimeo.com/channels/lexcoren>

COMMERCIAL BUILDING PRODUCTS

Ontario & Western Canada
1.800.268.2889



Quebec & Eastern Canada
1.800.363.2307